



**FITTING INSTRUCTIONS FOR DG0034 DOWNPIPE GRILLE
FOR HONDA CBR 500R 2019-**



PICTURE A

THIS KIT CONTAINS THE ITEMS PICTURED AND LABELLED OVER PAGE.

SOME PARTS MAY BE SHOWN FOR CLARITY OF INSTRUCTIONS ONLY.

DO NOT PROCEED UNTIL YOU ARE SURE ALL PARTS ARE PRESENT.

PLEASE READ ALL INSTRUCTIONS BEFORE PROCEEDING.

**IF IN ANY DOUBT WHEN FITTING OUR PRODUCTS, CONSULT ONE OF
OUR DEALERS OR HAVE FITTED BY A QUALIFIED TECHNICIAN.**

PLEASE NOTE THAT THE WAY THE KIT IS PACKED DOES NOT NECESSARILY REPRESENT THE
WAY OF MOUNTING TO THE BIKE.

IN THE EVENT OF RUBBER WASHERS BEING USED TO HOLD COMPONENTS ONTO BOLTS,
THESE RUBBER WASHERS CAN BE THROWN AWAY.

DIGITAL COPIES OF THESE INSTRUCTIONS ARE AVAILABLE FROM:

WWW.RG-RACING.COM



<u>TOOLS REQUIRED</u>	<u>GENERAL TORQUE SETTINGS</u>
<ul style="list-style-type: none"> • 10mm spanner or socket and wrench. • Set of metric Allen keys to include 4 & 5mm 	<p>M4 BOLT = 8Nm M5 BOLT = 12Nm M6 BOLT = 15Nm M8 BOLT = 20Nm M10 BOLT = 40Nm M12 BOLT = 40Nm</p>

LEGEND

ITEM NO.	DESCRIPTION	QTY
ITEM 1	DOWNPIPE GRILLE (DG0034)	1
ITEM 2	M6 x 35 LONG BUTTON HEAD BOLTS	2
ITEM 3	M6 NYLOC NUTS	3
ITEM 4	M6 WASHERS	4
ITEM 5	M6 x 15 LONG BUTTON HEAD BOLT	1

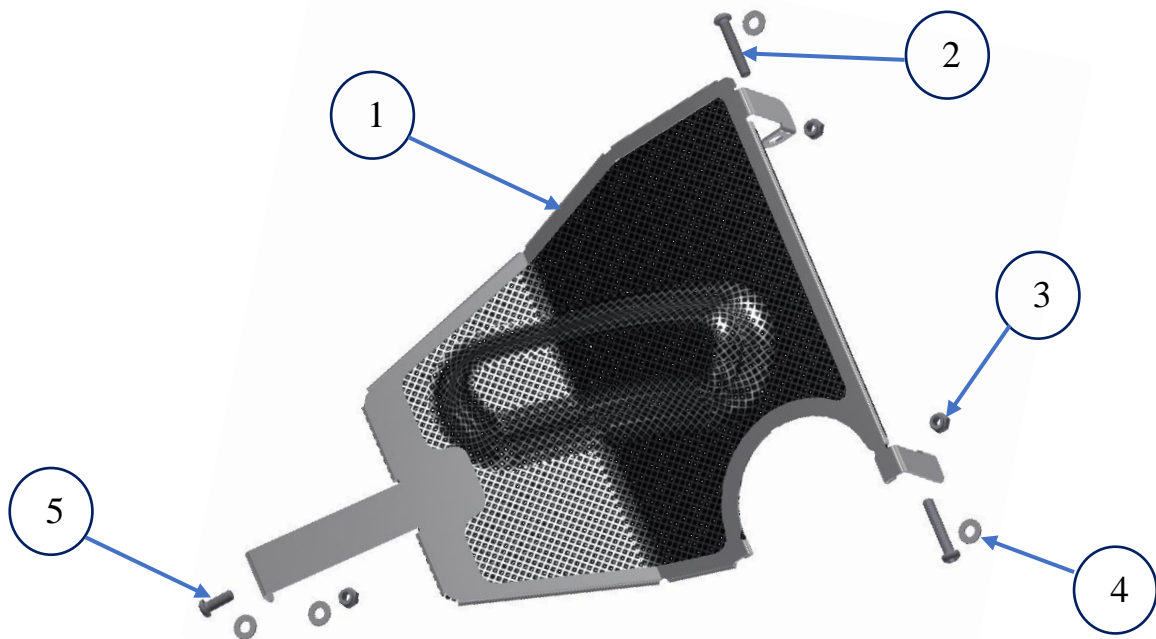

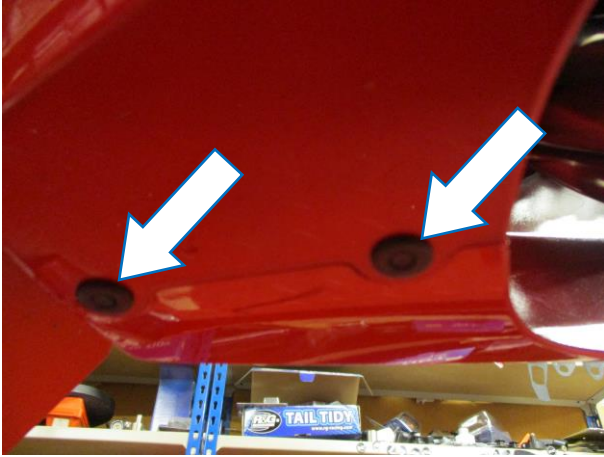

PICTURE 1



PICTURE 2



PICTURE 3

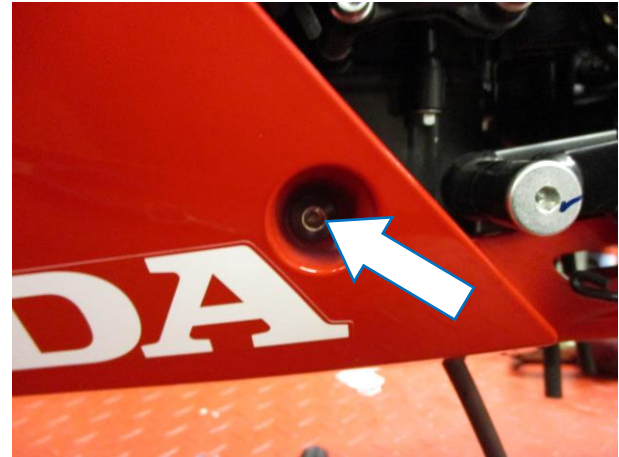

PICTURE 4

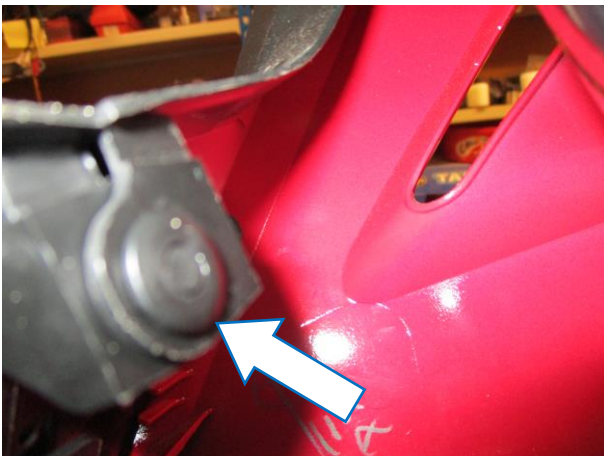

PICTURE 5

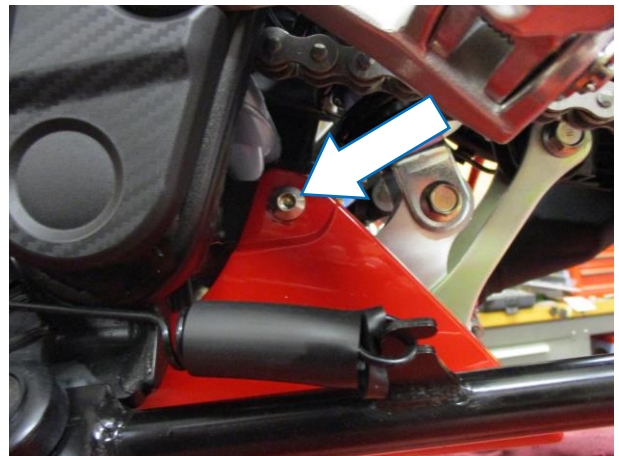

PICTURE 6

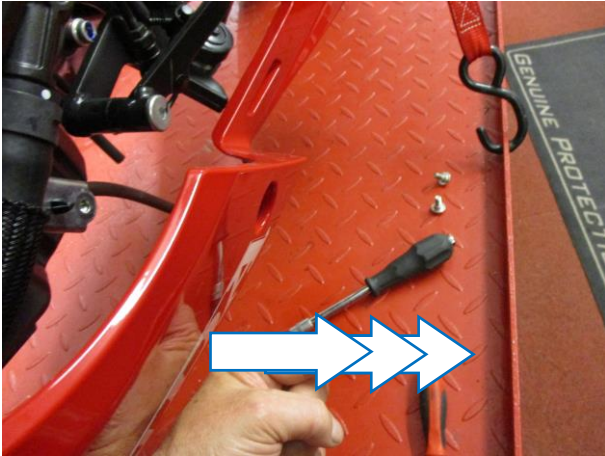

PICTURE 7



PICTURE 8



PICTURE 9

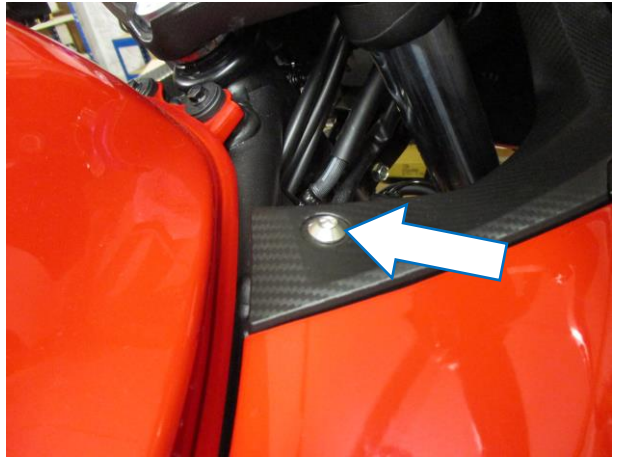

PICTURE 10

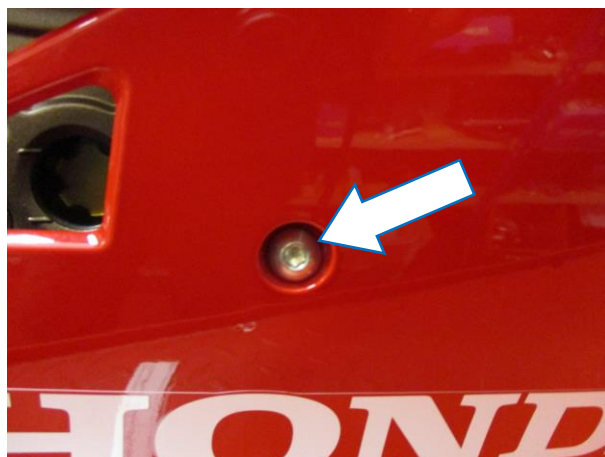

PICTURE 11



PICTURE 12

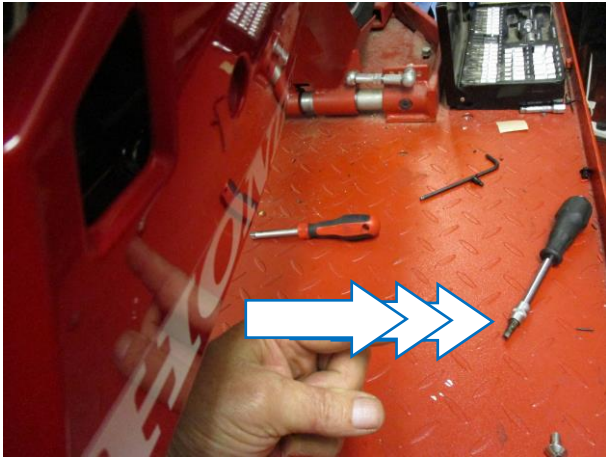

PICTURE 13

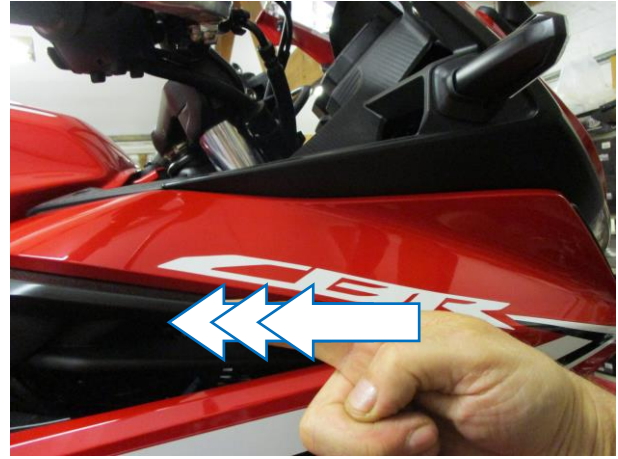

PICTURE 14

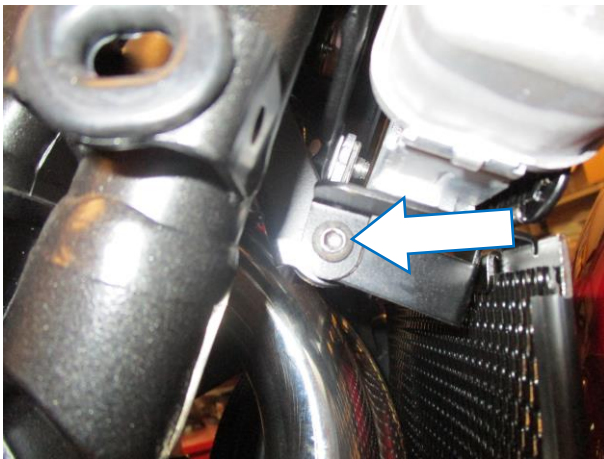

PICTURE 15

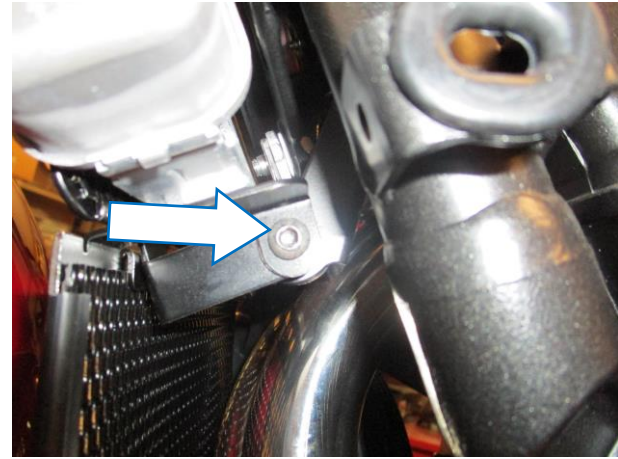

PICTURE 16

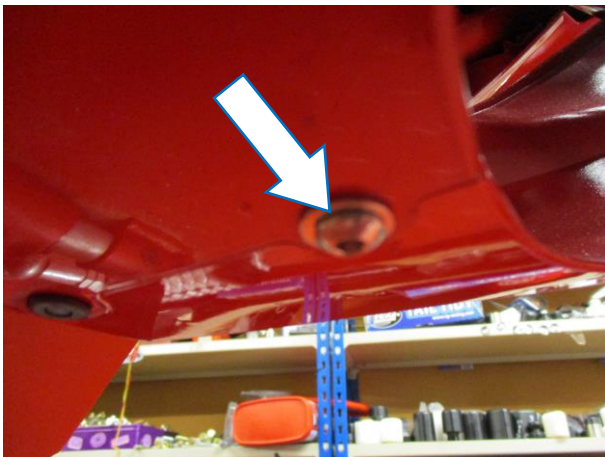

PICTURE 17

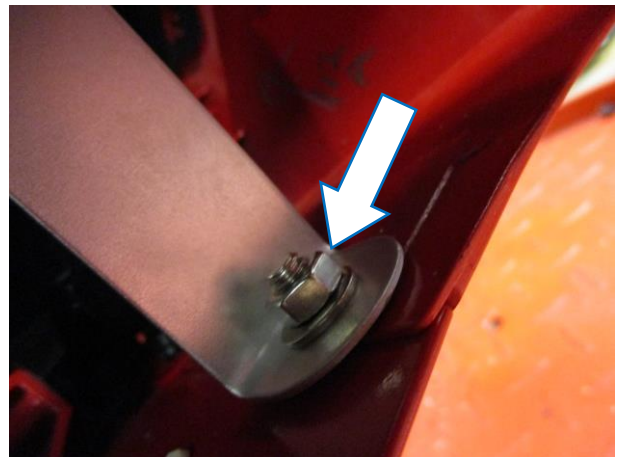

PICTURE 18



FITTING INSTRUCTIONS

Near side (left side as you sit on the motorcycle)

- Remove the three push rivets arrowed in **pictures 1 and 2**.
- Remove the two bolts arrowed in **pictures 3 and 4**.
- Remove the push rivet arrowed in **picture 5**.
- Remove the bolt arrowed in **picture 6**.
- Carefully and gently ease the fairing away from the engine to disengage the rubber locating stakes as shown in **picture 7**.
- Carefully and gently push the fairing rearwards to disengage the locating stakes as shown in **picture 8**.

Off side (right side as you sit on the motorcycle)

- Remove the push rivet arrowed in **picture 9**.
- Remove the three bolts arrowed in **pictures 10, 11 and 12**.
- Carefully and gently ease the fairing away from the engine to disengage the rubber locating stakes as shown in **picture 13**.
- Carefully and gently push the fairing rearwards to disengage the locating stakes as shown in **picture 14**.
- Offer the downpipe grille (**item 1**) into position and locate in position using the two longer button head bolts (**item 2**) with washers (**item 4**) as shown in **pictures 15 and 16**.
- Fit two of the nyloc nuts (**item 3**) to the exposed ends of both threads and tighten.
- Refit both fairings as original do not refit the push rivet in position arrowed in **picture 17**.
- Place one of washers (**item 4**) onto the remaining shorter button head bolt (**item 5**) then place this assembly through the empty hole as arrowed in **picture 17**.
- Use the remaining nut (**item 3**) and washer (**item 4**) to secure the bolt as shown in **picture 18** (do not over-tighten as damage can occur, the nyloc nut will hold it tight).

ISSUE 1 29/11/2019 (NSY)

CONSUMER NOTICE

The catalogue description and any exhibition of samples are only broad indications of the Products and R&G may make design changes which do not diminish their performance or visual appeal and supplying them in such state shall conform to the order. The Buyer acknowledges no representation or warranty (other than as to title) has been given or will apply to the Products other than those in R&G's order or confirmation and the Buyer confirms it has chosen the Products as being of merchantable quality and suitable for its particular purposes. Where R&G fits the Products or undertakes other services it shall exercise reasonable skill and care and rectify any fault free of charge unless the workmanship has been disturbed. The Buyer is responsible for ensuring that the warranty on the motorcycle is not affected by the fitting of the Products. On return of any defective Products R&G shall at its option either supply a replacement or refund the purchase money but shall not be liable if the Products have been modified or used or maintained otherwise than in accordance with R&G's or manufacturer's instructions and good engineering practice or if the defect arises from accident or neglect. Other than identified above and subject to R&G not limiting its liability for causing death and personal injury, it shall not be liable for indirect or consequential loss and otherwise its liability shall be limited to the amounts paid by the Buyer for the Products or the fitting or service concerned. These terms do not affect the Buyer's statutory rights.

R&G

Unit 1, Shelley's Lane, East Worldham, Alton, Hampshire, GU34 3AQ
Tel: +44 (0)1420 89007 Fax: +44 (0)1420 87301 www.rg-racing.com Email: info@rg-racing.com



R&G RETURNS POLICY (NON-FAULTY GOODS)

Returns must be pre-authorized (if not pre-authorized the return will be rejected). Goods may only be returned direct to us if they were purchased direct from us (customer must prove if necessary). Otherwise to be returned to original vendor. Goods must be in re-sellable condition, in the opinion of R&G. All returns are subject to a 25% restocking and handling fee (25% of the gross value exc. P&P – at the prevailing price at time of purchase). The customer must pay any and all carriage charges. No returns of discontinued products, unless within 14 days of purchase. This policy does not affect your statutory rights and does not refer to faulty goods.

R&G

Unit 1, Shelley's Lane, East Worldham, Alton, Hampshire, GU34 3AQ
Tel: +44 (0)1420 89007 Fax: +44 (0)1420 87301 www.rg-racing.com Email: info@rg-racing.com



NOTICE DE MONTAGE POUR DG0034
GRILLE DE PROTECTION COLLECTEURS D'ÉCHAPPEMENT
POUR HONDA CBR 500R 2019-



PHOTO A

LE KIT CONTIENT LES ARTICLES EN PHOTO ET ÉTIQUETTES SUR LA PAGE

LES PARTIES PRÉSENTÉES PEUVENT ÊTRE UNIQUEMENT REPRESENTATIVES POUR LA
CLARTE DES INSTRUCTIONS

NE PAS PROCÉDER AU MONTAGE AVANT DE VOUS ÊTRE ASSURÉ QUE TOUTES LES PIÈCES
SOIENT PRÉSENTES.

SVP, LIRE L'ENSEMBLE DE LA NOTICE AVANT DE PROCÉDER AU MONTAGE.

**EN CAS DE DOUTE LORS DU MONTAGE, CONSULTEZ UN DE NOS
REVENDEURS, OU FAITES EFFECTUER LE MONTAGE PAR UN
TECHNICIEN QUALIFIÉ.**

LA FAÇON DONT LE KIT EST EMBALLÉ NE CORRESPOND PAS FORCÉMENT À LA FAÇON DE
MONTER LES PIÈCES SUR LA MOTO.

NOTEZ QUE SI LES KITS SONT EMBALLÉS AVEC DES RONDELLES EN CAOUTCHOUC
SERVANT À TENIR LES COMPOSANTS, CES RONDELLES DOIVENT ÊTRE JETÉES.

NOTICE DISPONIBLE AU TÉLÉCHARGEMENT SUR :
WWW.RG-RACING.COM



<u>OUTILS REQUIS</u>	<u>VALEURS DE SERRAGE</u>
<ul style="list-style-type: none"> • Clé à molette 10mm. • Clés Allen 4 & 5mm 	M4 BOULON = 8NM M5 BOULON = 12NM M6 BOULON = 15NM M8 BOULON = 20NM M10 BOULON = 40NM M12 BOULON = 40NM

LEGENDE

ARTICLE NO.	DESCRIPTION	QTE
ARTICLE 1	GRILLE DE PROTECTION (DG0034)	1
ARTICLE 2	M6 x 35 BOULONS	2
ARTICLE 3	M6 ECROUS	3
ARTICLE 4	M6 RONDELLES	4
ARTICLE 5	M6 x 15 BOULON	1

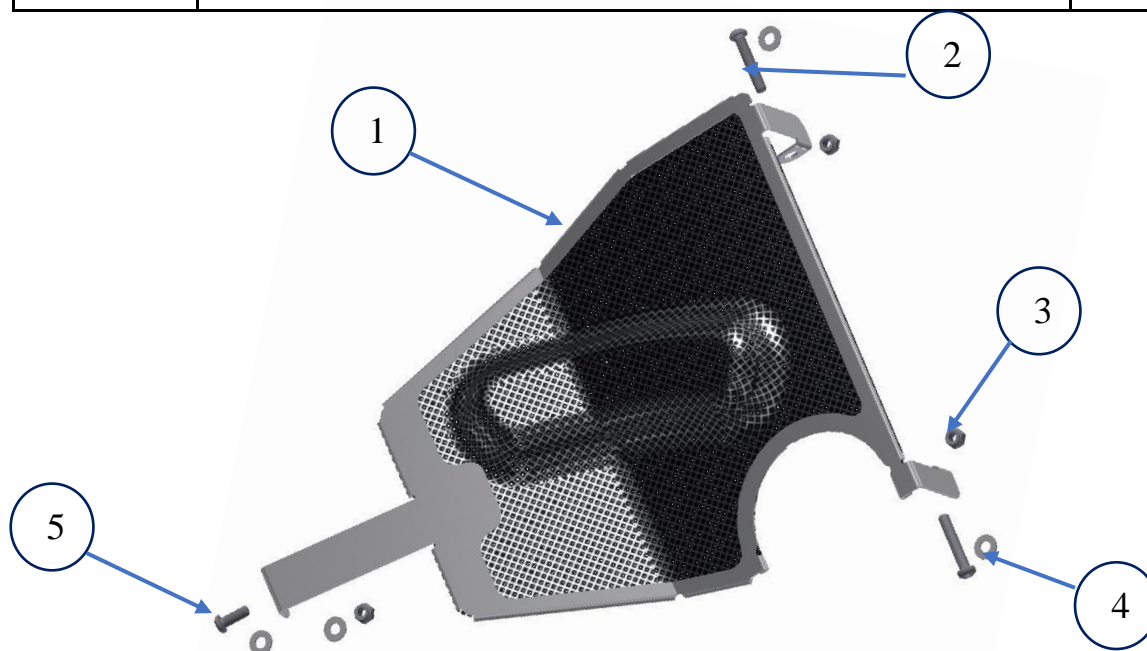

R&G



NOTICE DE MONTAGE

Coté gauche (Lorsqu'on est assis sur la moto)

- Retirez les trois rivets repérés par une flèche sur les photos 1 et 2.
- Retirez les deux boulons fléchés des photos 3 et 4.
- Retirez le rivet à pression indiqué par la flèche sur la photo 5.
- Retirez le boulon avec une flèche sur la photo 6.
- Dégagez délicatement le carénage du moteur pour dégager les tiges en caoutchouc, comme indiqué sur la photo 7.
- Poussez doucement et délicatement le carénage vers l'arrière pour dégager les piquets de positionnement, comme indiqué sur la photo 8.

Coté droit (Lorsqu'on est assis sur la moto)

- Retirez le rivet à pression indiqué par la flèche sur la photo 9.
- Retirez les trois boulons fléchés des photos 10, 11 et 12.
- Dégagez délicatement le carénage du moteur pour dégager les tiges en caoutchouc, comme indiqué sur la photo 13.
- Pousser doucement et délicatement le carénage vers l'arrière pour dégager les tiges, comme indiqué sur la photo 14.
- Placez la grille (article 1) en place et positionnez-la à l'aide des deux vis à tête ronde plus longues (article 2) avec rondelles (article 4), comme indiqué sur les photos 15 et 16.
- Fixez deux des écrous nyloc (article 3) aux extrémités exposées des deux filets et serrez.
- Remonter les deux carénages comme à l'origine, ne pas remettre le rivet à pression dans la position fléchée sur la photo 17.
- Placez une des rondelles (article 4) sur le dernier boulon à tête ronde (article 5), puis placez cet assemblage dans le trou vide indiqué par la flèche sur la photo 17.
- Utilisez l'écrou restant (article 3) et la rondelle (article 4) pour fixer le boulon comme indiqué sur la photo 18 (ne serrez pas trop fort car cela pourrait l'endommager, l'écrou nyloc le tiendra fermement).

ISSUE 1 29/11/2019 (NSY)